

**REACTION TO FIRE CLASSIFICATION REPORT
IN ACCORDANCE WITH PN-EN 13501-1:2019-02**

Contract no. 01196/25/Z00NZP

Sponsor:	WOODPLAST Sp. z o.o. ul. Lwowska 38 40-389 Katowice
Prepared by:	Zakład Badań Ogniwych Instytutu Techniki Budowlanej ul. Filtrowa 1 00-611 Warszawa
Product name:	The terrace system Bruggan Elegant
Classification report no.:	01196/25/Z00NZP-ENG
Issue number:	1
Date of issue:	11.06.2025

This classification report consists of five pages and may only be used or reproduced in its entirety.

1. Introduction

This classification report defines the classification assigned to terrace system Bruggan Elegant in accordance with the procedures given in PN-EN 13501-1:2019-02.

2. Details of classified product**2.1 General**

The product is defined as a terrace system and floor covering system for indoor and outdoor use.

2.2 Product description

The product, is described below.

Terrace system Bruggan Elegant consisting of solid composite board, aluminum joists and additional elements.

Board composition %:

- 50% wood flour,
- 30% polyethylene,
- 10% talc, .
- 10% functional additives,

Thickness of plank: 25 mm

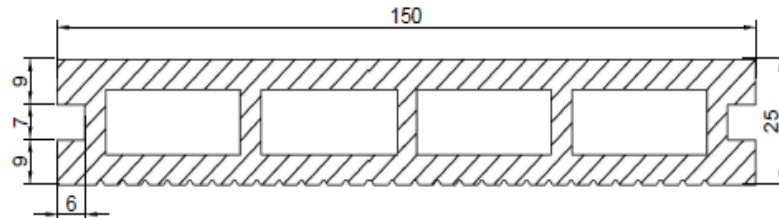

Fig. 1 Cross view of plank

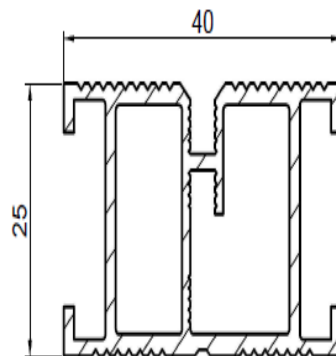

Fig.2 Cross view of an aluminum joist

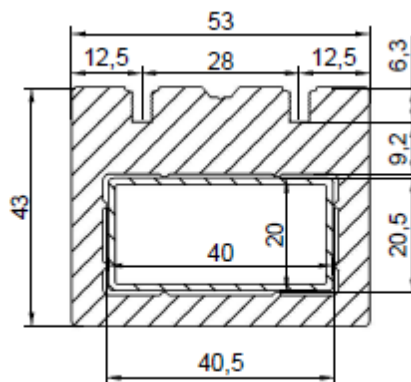

Fig.3 Cross view of an aluminum joist

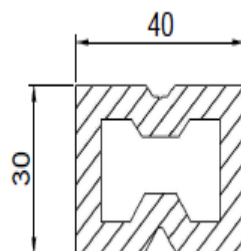

Fig.4 Cross view of an aluminum joist

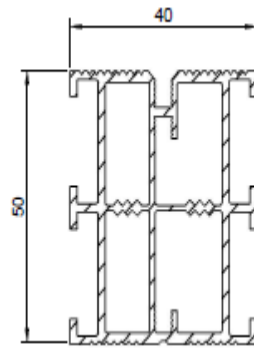

Fig.5 Cross view of an aluminum joist

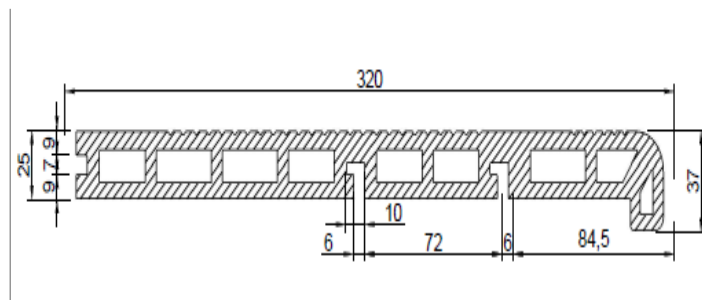

Fig 6 Additional elements

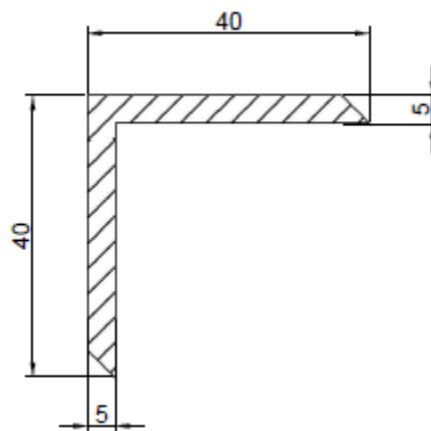

Fig 7 Additional elements

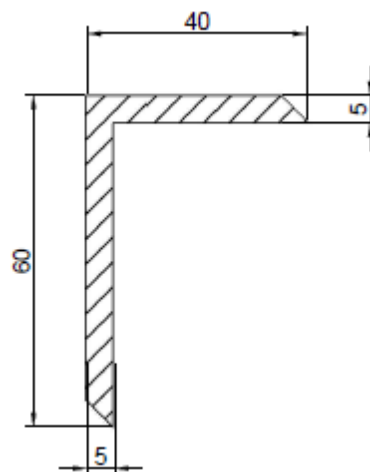

Fig 8 Additional elements

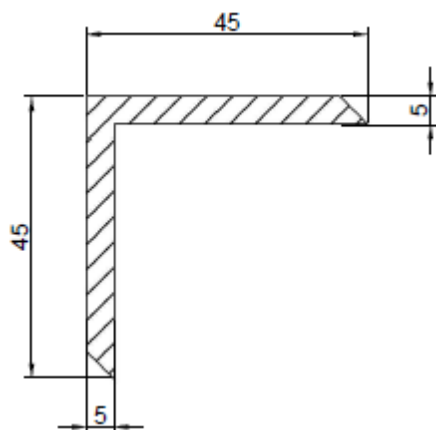

Fig 9 Additional elements

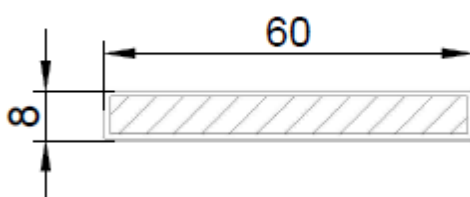

Fig 10 Additional elements

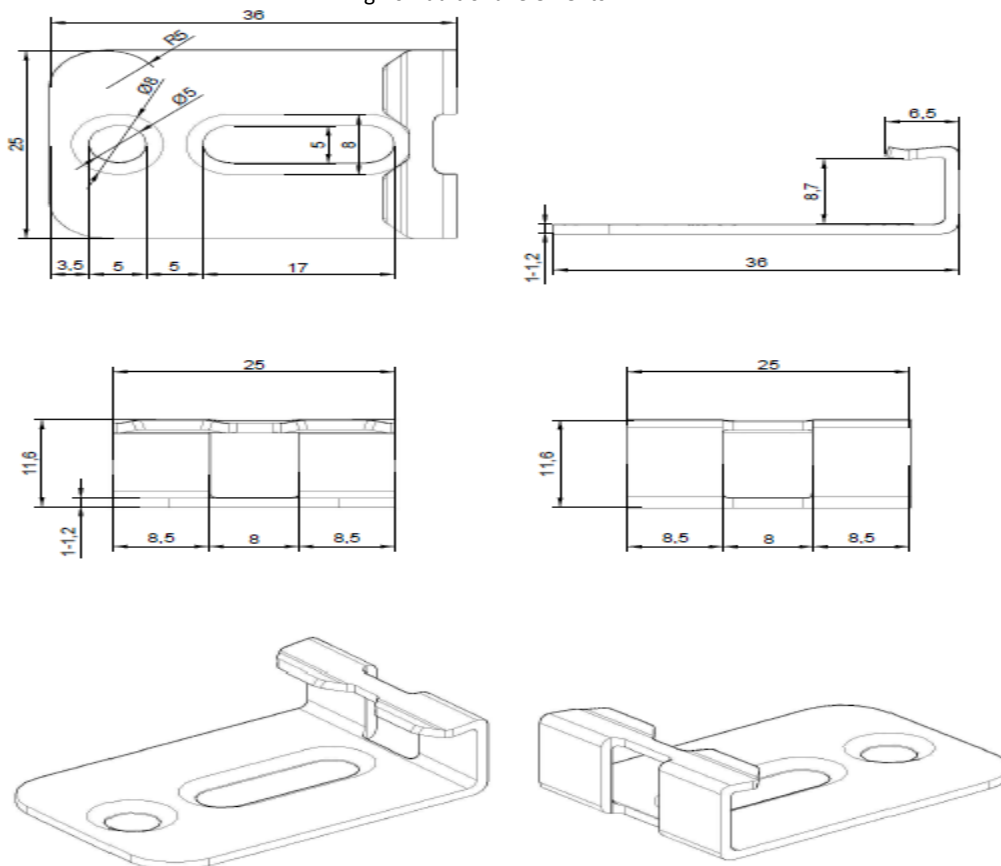

Fig 11 Additional elements

3. Test reports & test results in support of classification

3.1 Test reports

Name of laboratory	Name of sponsor	Test report no.	Test method
Fire Testing Laboratory of ITB	WOODPLAST Sp. z o.o.	LZP02-01196/25/Z00NZP	PN-EN ISO 11925-2:2020-09
		LZP01-01196/25/Z00NZP	PN-EN ISO 9239-1:2010

3.2 Test results

Test method	Parameter	Number of tests	Results	
			Continuous parameter – mean (m)	Compliance with parameters
PN-EN ISO 11925-2:2010 Exposure 15 s	$F_s \leq 150$ mm	6	(-)	Y
PN-EN ISO 9239-1:2010	Critical heat flux (kW/m ²)	3	11,0	(-)
	Smoke production (%·min)		3,0	(-)

(-): do not concern
Y: Yes N: No

4 Classification and field of application

4.1 Reference of classification

This classification has been carried out in accordance with PN-EN 13501-1:2019-02.

4.2 Classification

Terrace system Bruggan Elegant, in relation to its reaction to fire behaviour is classified:

B_{fl}

The additional classification in relation to smoke production is:

s1

The format of the reaction to fire classification for floorings is:

Fire behaviour		Smoke production	
B_{fl}	-	s	1

i.e.: **B_{fl}-s1**

Reaction to fire classification: **B_{fl}-s1**

4.3 Field of application

This classification is valid for the following product parameters:

- Product described in point 2 this classification report
- Terrace system Bruggan Elegant used on substrates with reaction to fire class A1 and A2 acc. to PN-EN 13501-1.

5 Limitation

The classification given above remains valid as long as:

- test method remains unchanged,
- product standard or technical approval remains unchanged,
- constructional or material modifications do not exceed limits of the field of application defined in 4.3.

This classification document does not represent type approval or certification of the product.

This classification report has been issued in electronic form, with qualified electronic signatures of responsible persons. The printout of this report is not an original document. A document bearing a qualified electronic signature whose certificate has already expired is still valid (the certificate was valid on the day the document was signed). Additional signed copies can be issued by Fire Research Department of ITB on the request of the report's owner only.

Classification	Name	Date	Signature
Prepared by	Mariusz Żońnik.	11.06.2025	e-signature
Verified by:	Bartłomiej K. Papis PhD. Eng.	11.06.2025	e-signature

Head of Fire Research Department
Bartłomiej K. Papis PhD. Eng.
e-signature